

To Significantly Cut Metal Losses ...

The importance of metal quality varies from plant to plant and from one job to the next. Today many methods are used by aluminum casters to improve their metal quality. Possibly the most overlooked yet significant factor in metal quality is the melting equipment used.

Looking back to our high school chemistry, we are reminded that a fossil fuel such as natural gas, burning in an aluminum melting furnace, produces water vapor – one of several combustion by-products – creating highly adverse conditions for maintaining good metal quality.

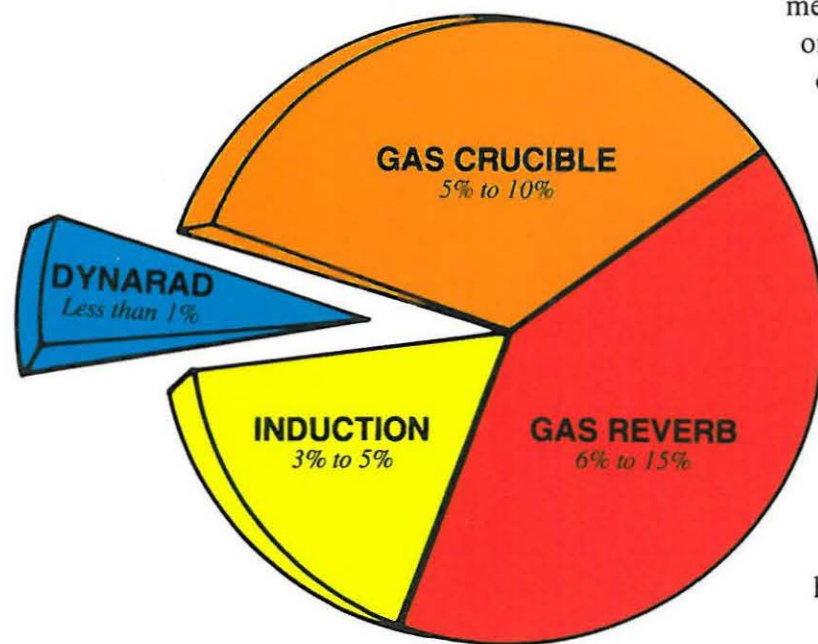

We know from experience that molten aluminum and water don't mix, but react with each other explosively. Thus, we shouldn't find it surprising that this same reaction takes place continuously with the same intensity, though on a much smaller scale, whenever water vapor and molten aluminum contact each other to form aluminum oxide (dross) and free, gaseous hydrogen.

Conversion to Dynarad® electric melting eliminates these adverse melting conditions with many aluminum casters reporting a 75% to 80% melt loss reduction. When this percentage is multiplied by the annual production of a typical casting plant, and by today's aluminum prices, the resulting savings are significant!

MELT LOSSES ERODE PROFIT DOLLARS

To Deliver the Ultimate In Power Supply Reliability ...

New!

PIGGYBACK™ POWER SUPPLY

Dynarad® combines the best in 100% solid state control with the time proven durability of a rugged contactor backup system.

Dynarad's Piggyback™ Power Supply virtually eliminates power supply downtime: If the solid state power controller requires servicing, it can be completely removed in minutes and the furnace will continue operating indefinitely at all power levels using the backup contactors!

PIGGYBACK™ SYSTEM includes:

- Reliable SCR power controller
- Set of heavy duty sealed backup contactors
- True load shedding Power Level Selector
- Seven day timer for programmed startup
- High & Low metal temperature alarms
- Ground fault interrupter
- Metal leak detector



All designs and specifications subject to change without notice.

DYNARAD
INNOVATIVE ENGINEERING

SALES OFFICES
575 Whitney Street
San Leandro, California 94577
Telephone: (510) 638-2000
FAX: (510) 639-4564
Telex: 296231

MANUFACTURING FACILITIES
575 Whitney Street
San Leandro, California 94577
Telephone: (415) 638-2000
FAX: (415) 639-4564
Telex: 296231

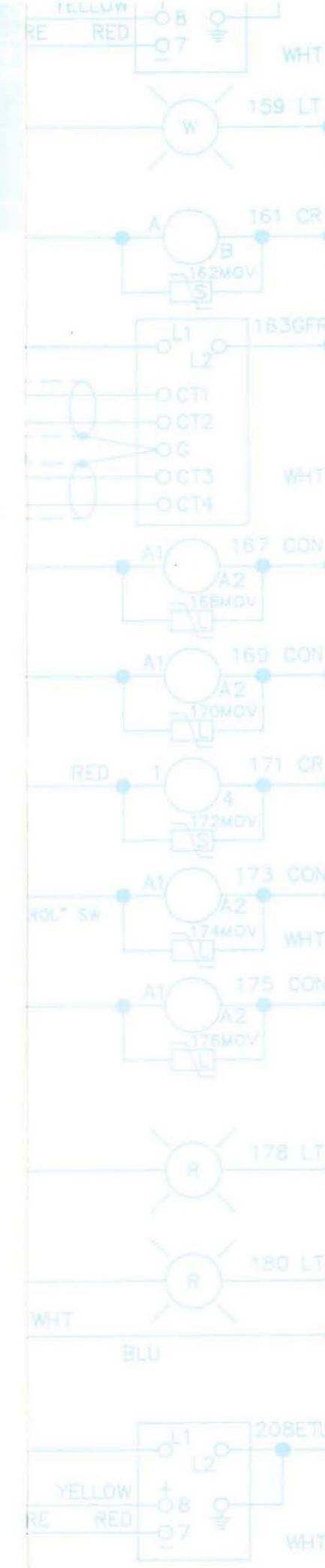

DYNARAD
INNOVATIVE ENGINEERING

*Industry's First Choice For
High Performance Melting Equipment*

